

**THE PARAMETERS COMPUTER OF THE TWO-MEASURING
 ELECTRO MAGNETIC SENSOR OF TRANSFERENCES**

Firudin Mammadov¹, Rena Asadova²

Institute of Cybernetics of ANAS, Baku, Azerbaijan
¹MamedovFirudin@rambler.ru, ²RenaAsadova2007@rambler.ru

The authors of the article created two-measured electromagnetic sensor for simultaneous dimension of linear and angular transferences with the alone sensor. The unfold of the sensor is shown on the picture 1. The present sensor contains the cylindrical magnet conductor 1; inside of the magnet conductor allocates the ferromagnetic rotor 2, which has form of thin-walled demi-cylinder, the unfold of which is represented as a rectangle.

In the longitudinal grooves 3 of the magnet conductor 1 have sections 4 and 5 of the primary winding excitation and sections 6 and 7 of the second winding for dimension of linear transferences, along the longitudinal axle of the transformation. In diametrical allocating grooves on the internal face of the magnet conductor 1 allocates sections 8 and 9 of primary winding excitation and sections 10 and 11 of the second winding for dimension of angular transferences β relativity of the second winding for dimension of angular transferences β relativity of longitudinal axle of the rotor 2 revolving of the transformation. The sections of the second winding for dimension of linear and angular transferences are connected by means of the differential scheme. The sections 4,5 and 8,9 of the primary winding are connected connects in each pair sequentially- compliance and are fed from the strain source of alternating current.

The inductive transformation of linears and angular transferences works in the following form.

In the initial position of the rotor 2, when it allocates symmetrically of relative sections 4-11 of primary and the second winding for dimension linear and angular transferences in the sections 6,7 and 10,11, difference of the electro moving power is equally to zero.

During a turn of the rotor 2 around axle on the corner β , for example, by direction of an hour pointer is enlarged area of a sections recover 8 and 10 by means of the rectangling ferromagnet's rotor 2 and suitable is lessen area of a recover of the sections 9 and 11 of primary and the second winding for dimension of angular transferences. Therefore in the section 10, the electro moving power value is enlarged, and in the section 11 is lessen and supporting a signal ΔE_1 , proportioning transferences of angular ΔE_y of the rotor 2 on the one of outsides of the transformation.

Electric magnet fields $\Phi_{y\delta}^l$ of each winding system made by each system of winding are fase-paralld and are closed up as on picture 2.

On the basics of the picture 2, thickens of middle projection of the goof depending on a depth of electromagnet field in the magnet conductor solid. During research is definited that a depth of electromagnet field in steel is option 3 mm, when alike 50 Gz.

During the middle projection of the goof in a two-side electric-magnet field, then it thickness can be approximately 5, 6 mm.

And so in the middle projection the electromagnet field can be described by means of serials differential in the expression of second sequence for linear transference chain, where H is a symbol as H_y . The thinness of the middle of the projection, where is marked the point O. During $X=+d$ and $A_1=A_2=A$ the last expression is written in the view:

$$H_y^l = 2Achx \quad (1)$$

During $X=d$; $H_y^l = H_{56m}^l = H_5$ and to definite A and write the expression of the magnet which is closed up over the middle projection with H_y^l have:

$$\Phi_y^l = \frac{2\mu\mu_0 H_{56m}^l \alpha_0}{k} thkd \quad (2)$$

The magnet conductor is directed to the conductors Φ_1^l and Φ_2^l . For finding these sells the coordinate system is replaced to the point O_l , which is the outside phase of a moving magnet contact.

In this field face is described as the same by means of the serial usual differential expression.

$$H_{x1}^l = B_1 e^{ky_1} + B_2 e^{-ky_1} \quad (3)$$

The field can not increased at the end in the envisaging section of the moving magnets conductor, therefore $B=0$ and the expression (3) is written in the view:

$$H_{x1}^l = B_2 e^{-ky_1} \quad (4)$$

From the decision of the electromagnet field expression will be

$$H_{x1} = H_{12m}^l e^{-ky_1} \quad (5)$$

The magnet conductor Φ_1^l with a appliance (3) has the view:

$$\Phi_1^l = \mu\mu_0 H_{12m} \alpha (1 - e^{-k\Delta_1}) / k \quad (6)$$

The magnet conductor Φ_2^l is defined of the same:

$$\Phi_2^l = \mu\mu_0 H_{1'2'm} \frac{\alpha_0}{k} (1 - e^{-k\Delta_1}) \quad (7)$$

The magnets Φ_1^l is allocates in the right point of aerial expanse of the transducer, and Φ_2^l in the left point of aerial expanse. The left and right points are taken relatively of middles projections of the grooves.

Using the principle of the magnets sell continuous for elementary magnet small pipe, where (during that) one section is on the areas $X=0$, and second section is on the middle of the right aerial expanse, well get the following expression:

$$H_{X_1=0}^l = \frac{B_0}{a_0} \frac{H_{y\delta}^l}{\mu} \frac{dx_1}{dy_1} \quad (8)$$

$$\frac{d^3 x_1}{d_1 y_1^3} = k^2 \frac{dx_1}{dy_1} \quad (9)$$

After definition the integrating constants will get:

$$X_1 = \alpha + \frac{b_0}{Shk\Delta_1} shky_1 \quad (10)$$

From that expression will get:

$$\frac{dx_1}{dy_1} = \frac{b_0 k}{Shk\Delta_1} chky_1 \quad (11)$$

Appreciate (11) in (8), and to use (4) and to express qiperbolic cosines by means of the presentqs functions and after some transformations will get the following:

$$H_{y_1\delta_1}^l = \frac{2shk\Delta_1\alpha_0}{kb_0^2} \mu \frac{H_{12m}^l e^{-2ky_1}}{1+e^{-2ky_1}} \quad (12)$$

By means of (10) is definite $Shky$ and $Chky$ and write their as presents functions and use for e^{2ky_1} the approaching expression

$$\sqrt{1 + \frac{1}{q^2}} = 1 + \frac{1}{2q^2}$$

And after some calculating will get the following

$$H_{y_1\delta_1}^l = \frac{2\alpha_0 shk\Delta}{kb_0^2} \mu H_{12m}^l \frac{1}{1+\{(X_1-\alpha)m_0\}^2} \quad (13)$$

With use (13) will find the magnet conductor, of passing over magnet expanse, which write in the view:

$$\Phi_{y_1\delta} = \mu\mu_0 H_{12b}^l \frac{\alpha_0^2}{k_m R b_0} \arctg \{2m_0 (b_0 - \alpha + x)\} \quad (14)$$

The magnet conductor in the left side of the winding is definite of the same method. During dimension of the liners transference moving magnet contact is getting transference by axis and therefore recluse of the winding system 2 is enlarge and the winding system 2 is lessen. Therefore the expression (14) for the magnet conductor of passing across the winding and write in the view:

$$\Phi_{H_1\delta} = \mu\mu_0 \frac{(\alpha_0+Z)^2}{kb_0} H_{12m}^l \arctg \frac{4m_0(b_0-\alpha)}{1-4m_0^2\{(b_0-\alpha)^2-X^2\}} \quad (15)$$

And magnet conductors $\Phi_{Y_1\delta}$, of passing across 2,2' have the view:

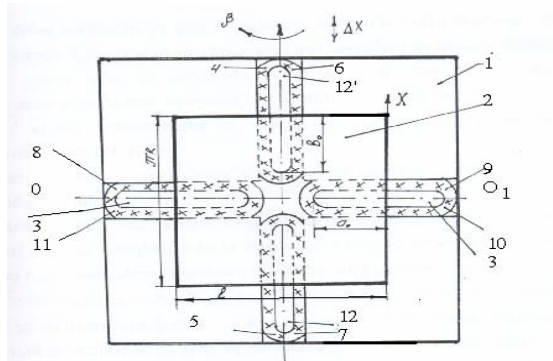

Fig. 1. The two functional electromagnet sensor in a unfold

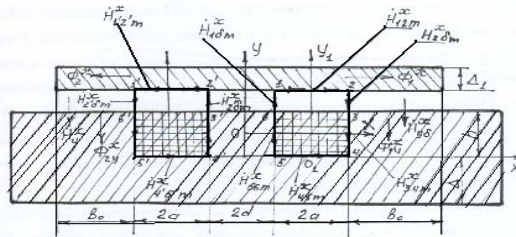

Fig. 2. The electromagnet field round a sensor

$$\Phi_{Y_1\delta} = \mu\mu_0 \frac{(\alpha_0-Z)^2}{kb_0} H_{12m}^l \arctg \frac{4m_0(b_0-\alpha)}{1-4m_0^2\{(b_0-\alpha)^2-Z^2\}} \quad (16)$$

The systems of dimension the winding 2 and 2' are connected by differential scheme, therefore inducing the Electro moving power in these windings will be:

$$\Delta E_l = -jW_{2l} \omega \mu\mu_0 \frac{H_{12m}^l}{kb_0} \alpha_0 Z \arctg \frac{4m_0(b_0-\alpha)}{1-4m_0^2\{(b_0-\alpha)^2-X^2\}} \quad (17)$$

E is proportioning transference of moving magnet contact by the exit Z . By means of the a for e said Principe we find magnet conductor of passing the 6 and 7 in the chain of angular transference, which writes as

$$\Phi_{Y_x}^y = \mu\mu_0 \frac{(b_0+X)^2}{kx_0} H_{12m}^y \arctg \frac{4m_0(\alpha_0-\alpha)}{1-4m_0^2\{(\alpha_0-\alpha)^2-Z^2\}} \quad (18)$$

Electro motive force of inducing in the clutch's of dimension the winding systems 6 and 7 are connected between themselves by the differential scheme and therefore

$$\Delta E_y = -jW_{2y} \omega \mu\mu_0 \frac{b_0}{k\alpha_0} H_{12m}^y \arctg \frac{4m_0(\alpha_0-\alpha)}{1-4m_0^2\{(\alpha_0-\alpha)^2-Z^2\}} \quad (19)$$

where $X=\beta R_n$, R_n is the external radius of the moving magnet conductor; β is the angular of a turn. Therefore ΔE_y is directly proportioning turn angular of the moving magnet conductor.

From (15) and (18) is followed that between dimensions chains of linear and angular transferences has a functioning link.

During a perform a condition $1-m_0^2\{\alpha_0-\alpha\}^2 \gg 4m_0^2Z^2$ can get a minimal mutual influence between dimensions chains.

As shown (17) and (20) ΔE_l and ΔE_y values can be written if the values H_{12m}^l and H_{12m}^y are well known. Using the status of common current for 1,2,3...n counters (pict.2) and Principe of the magnet conductor continuous finds tensions and to determine to the expressions (17) and (19) will get the Electro moving power formal in each exit of dimensions chains, which writes in the view:

$$\Delta E_l = -j\omega W_{2l} \frac{2\mu\mu_0\alpha_0Z}{kb_0} \frac{I_l W_l}{\{1+\alpha_2\}2\alpha+\{n_0\mu n_1\}\delta+\{\frac{n_0}{\mu}+n_1\}n} \times$$

$$\times \operatorname{arctg} \frac{4m_0\{b_0-\alpha\}}{1-4m_0^2\{(b_0-\alpha)^2-X^2\}} \quad (20)$$

$$\Delta E_y = -j\omega W_{2y} \frac{2\mu\mu_0b_0X}{k\alpha_0} \frac{I_y W_y}{\{1+\alpha_2\}2\alpha+\{n_0\mu n_1\}\delta+\{\frac{n_0}{\mu}+n_1\}n} \times$$

$$\times \operatorname{arctg} \frac{4m_0\{\alpha_0-\alpha\}}{1-4m_0^2\{(\alpha_0-\alpha)^2-Z^2\}} \quad (21)$$

Geometrical dimensions of the magnet conductor received by the formula (20), (21) can compensate inter influence among dimension chains.

References

1. Asadova R.Sh., Mamedov F.I., Asadova K.F. “Inductive transformer of linear and angular transference”, Patent of the Azerbaijan Republic, 2008, 005, Baku, 2008.
2. Mamedov F.I., Mamedov J.F., Asadova R.Sh. Analytic investigation of optimal parameters of two-functional electromagnet transducers with continuous magnet conductor. Works of II International Symposium “Problems of mathematic modeling, controlling and information technologies in oil-gas industry”, News of National Academy Of Sciences Of Baku, 21-26 September, 1998, pp.101-103
3. Mamedov F.I., Asadova R.Sh., Sattarov V.K., Mamedov J.F. “Two –functional inductive transducer of linear and angular transferences. Patent of the Azerbaijan Republic, 990049, Baku, Printed in B.I., 1998.